



MC34063A

LINEAR INTEGRATED CIRCUIT

DC TO DC CONVERTER CONTROLLER

DESCRIPTION

The UT C **MC34063A** is a monolithic r egulator s ubsystem, intended for use as D C to D C converter. This device contains a temperature c ompensated b and gap refer ence, a dut y-cycle control oscillator, driver and high current output switch. It can be used for step do wn, step-up or in verting switching regulators as well as for series pass regulators.

FEATURES

- * Operation from 3.0V to 40V.
- * Short circuit current limiting.
- * Low standby current.
- * Output switch current of 1.5A without external transistors.
- * Frequency of operation from 100Hz to 100kHz.
- * Step-up, step-down or inverting switch regulators.

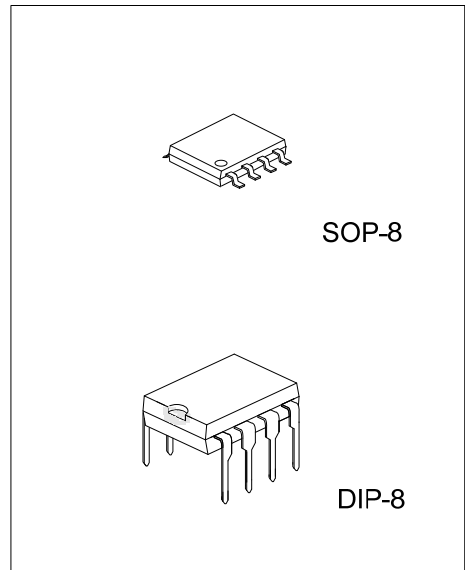

ORDERING INFORMATION

Ordering Number		Package	Packing
Lead Free	Halogen Free		
MC34063AL-D08-T MC340	63AG-D08-T	DIP-8	Tube
MC34063AL-S08-R MC340	63AG-S08-R	SOP-8	Tape Reel
MC34063AL-S08-T MC340	63AG-S08-T	SOP-8	Tube

<p>MC34063AL-D08-T</p> <p>(1)Packing Type (2)Package Type (3)Lead Free</p>	<p>(1) T: Tube, R: Tape Reel (2) D08: DIP-8, S08: SOP-8 (3) G: Halogen Free, L: Lead Free</p>
--	---

■ ABSOLUTE MAXIMUM RATINGS (T_A=25°C, unless otherwise specified.)

PARAMETER		SYMBOL	RATINGS	UNIT
Supply Voltage		V _{CC}	40	V
Comparator Input Voltage		V _{IN(COMP)}	-0.3 ~ +40	V
Switch Collector Voltage		V _{C(SW)}	40	V
Switch Emitter Voltage		V _{E(SW)}	40	V
Switch Collector to Emitter Voltage		V _{CE(SW)}	40	V
Driver Collector Voltage		V _{C(DR)}	40	V
Switch Current		I _{SW}	1.5	A
Power Dissipation (T _A =25°C)	DIP-8	P _D	1250	mW
	SOP-8		625	
Junction Temperature		T _J	+150	°C
Operating Temperature		T _{OPR}	0 ~ +70	°C
Storage Temperature		T _{STG}	-65 ~ +150	°C

Note: Absolute maximum ratings are those values beyond which the device which the device could be permanently damaged. Absolute maximum ratings are stress ratings only and functional device operation is not implied.

■ THERMAL DATA

PARAMETER		SYMBOL	RATINGS	UNIT
Junction-to-Ambient	DIP-8	θ _{JA}	100	°C/W
	SOP-8		160	

■ ELECTRICAL CHARACTERISTICS (V_{CC}=5.0V, T_A=0~+70°C, unless otherwise specified.)

PARAMETER	SYMBOL	TEST CONDITIONS	MIN	TYP	MAX	UNIT
OSCILLATOR						
Charging Current	I _{CHG}	V _{CC} =5 to 40V, T _A =25°C	22	31	42	μA
Discharging Current	I _{DISCHG}	V _{CC} =5 to 40V, T _A =25°C	140	190	260	μA
Oscillator Amplitude	V _{OSC}	T _A =25°C	0.5			V
Discharge to Charge Current Ratio	K	V ₇ =V _{CC} , T _A =25°C	5.2	6.1	7.5	
Current limit Sense Voltage	V _{SENSE}	I _{CHG} =I _{DISCHG} , T _A =25°C	250	300	350	mV
OUTPUT SWITCH						
Saturation Voltage 1 (Note)	V _{CE(SAT)1}	I _{SW} =1.0A, V _{C(DRIVER)} =V _{C(SW)}		0.95	1.3	V
Saturation Voltage 2 (Note)	V _{CE(SAT)2}	I _{SW} =1.0A, V _{C(DRIVER)} =50mA		0.45	0.7	V
DC Current Gain (Note)	G _{I(DC)}	I _{SW} =1.0A, V _{CE} =5.0V, T _A =25°C		180		
Collector Off State Current (Note)	I _{C(OFF)}	V _{CE} =40.0V, T _A =25°C		0.01	100	μA
COMPARATOR						
Threshold Voltage	V _{THD}		1.21	1.25	1.29	V
Threshold Voltage Line Regulation	V _{THD}	V _{CC} =3 ~ 40V		2.0	5.0	mV
Input Bias Current	I _{I(BIAS)}	V _{IN} =0V		50	400	nA
TOTAL DEVICE						
Supply Current	I _{CC}	V _{CC} =5~40V, C _T =0.001 V ₇ =V _{CC} , V _C >V _{THD} , Pin2=GND	2.7		4.0	mA

Note: Output switch tests are performed under pulsed conditions to minimize power dissipation.

■ STEP-UP CONVERTER

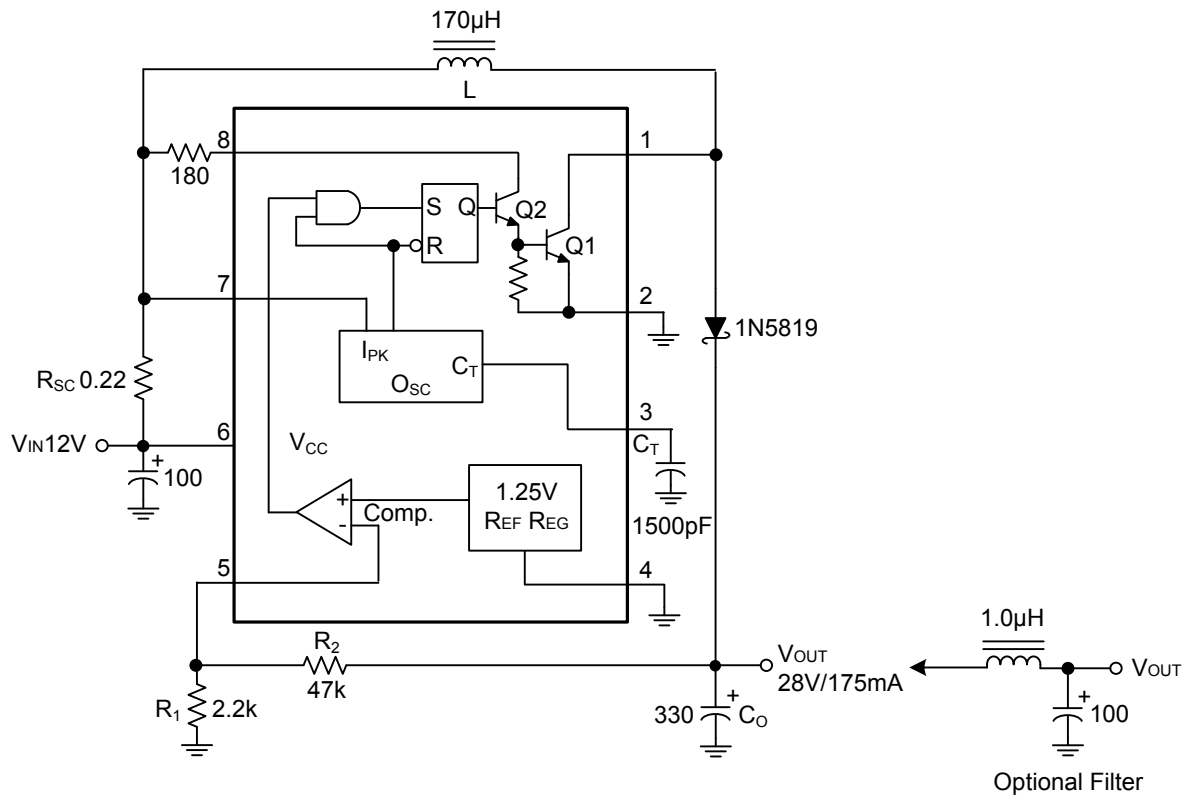

TEST CONDIT	IONS	RESULTS
Line Regulation	$V_{IN} = 8.0V \sim 16V, I_{OUT} = 175mA$	$30mV = \pm 0.05\%$
Load Regulation	$V_{IN} = 12V, I_{OUT} = 75mA \sim 175mA$	$10mV = \pm 0.017\%$
Output Ripple	$V_{IN} = 12V, I_{OUT} = 175mA$	$400mV_{P-P}$
Efficiency	$V_{IN} = 12V, I_{OUT} = 175mA$	87.7%
Output Ripple With Optional Filter	$V_{IN} = 12V, I_{OUT} = 175mA$	$40mV_{P-P}$

■ STEP-DOWN CONVERTER(Cont.)

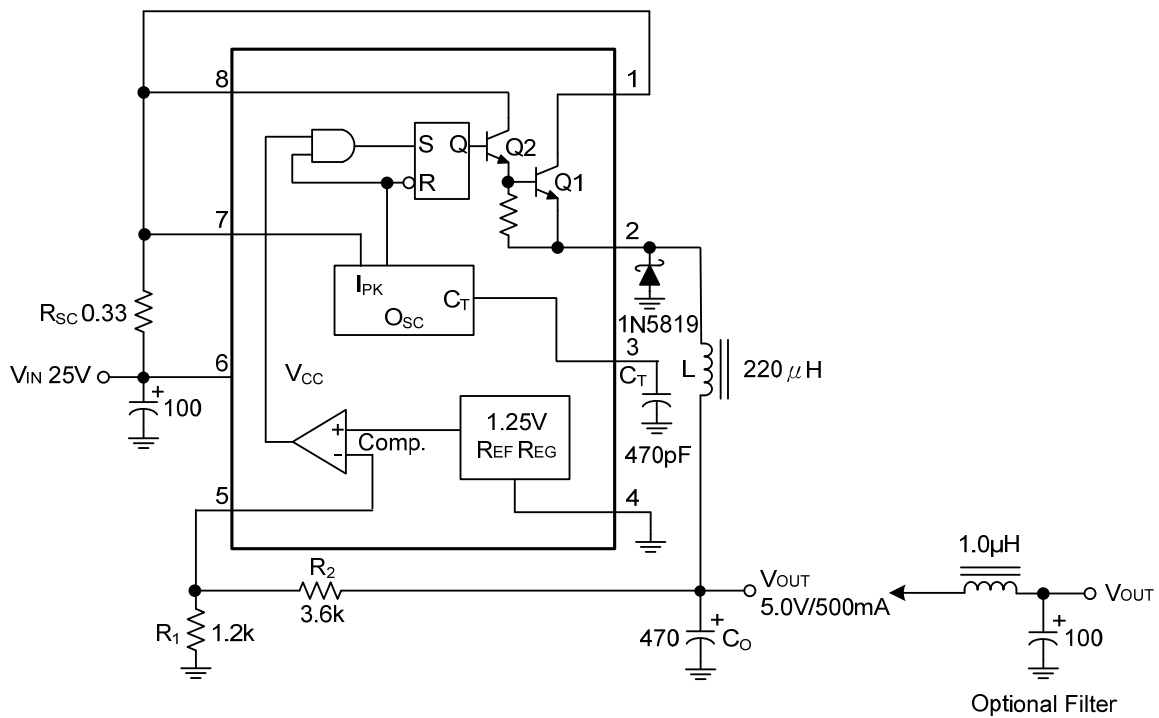

TEST CONDIT	IONS	RESULTS
Line Regulation	$V_{IN} = 15V \sim 25V, I_{OUT} = 500mA$	$12mV = \pm 0.12\%$
Load Regulation	$V_{IN} = 25V, I_{OUT} = 50mA \sim 500mA$	$3.0mV = \pm 0.03\%$
Output Ripple	$V_{IN} = 25V, I_{OUT} = 500mA$	$120mV_{P-P}$
Short Circuit Current	$V_{IN} = 25V, R_L = 0.1\Omega$	1.1A
Efficiency	$V_{IN} = 25V, I_{OUT} = 500mA$	83.7%
Output Ripple With Optional Filter	$V_{IN} = 25V, I_{OUT} = 500mA$	$40mV_{P-P}$

■ VOLTAGE INVERTING CONVERTER

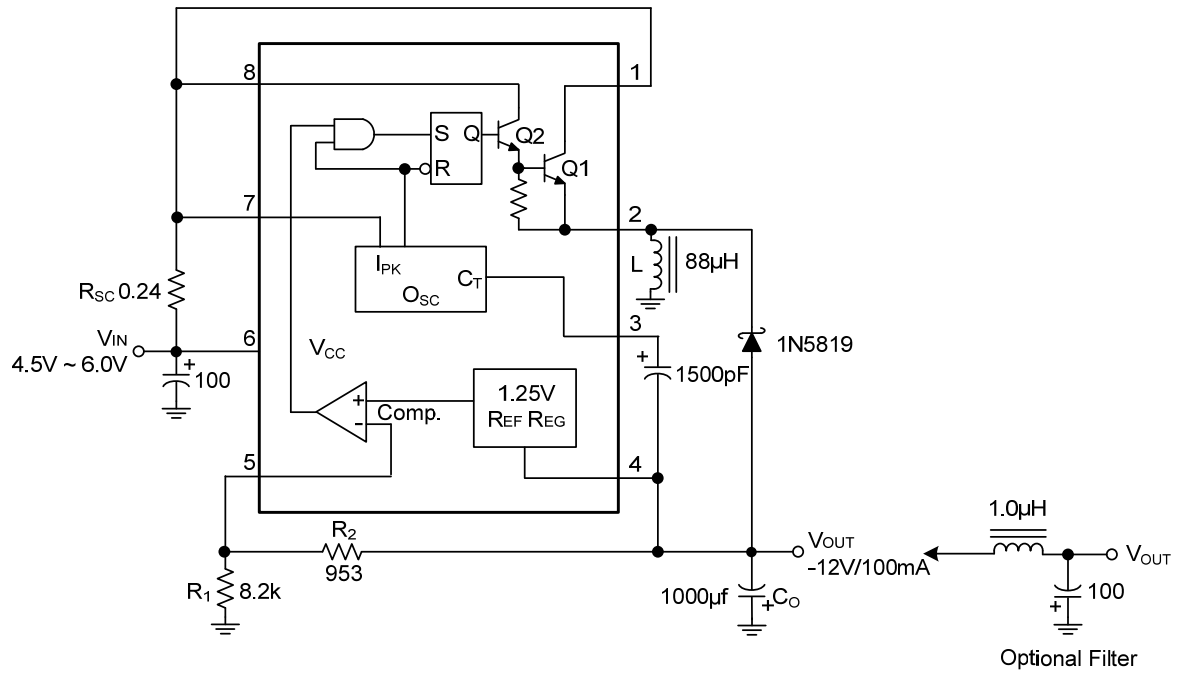

TEST CONDIT	IONS	RESULTS
Line Regulation	$V_{IN} = 4.5V \sim 6.0V, I_{OUT} = 100mA$	$3.0mV = \pm 0.012\%$
Load Regulation	$V_{IN} = 5.0V, I_{OUT} = 10mA \sim 100mA$	$0.022V = \pm 0.09\%$
Output Ripple	$V_{IN} = 5.0V, I_{OUT} = 100mA$	$500mV_{P-P}$
Short Circuit Current	$V_{IN} = 5.0V, R_L = 0.1\Omega$	$910mA$
Efficiency V	$I_N = 5.0V, I_{OUT} = 100mA$	62.2%
Output Ripple With Optional Filter	$V_{IN} = 5.0V, I_{OUT} = 100mA$	$70mV_{P-P}$

■ EXTERNAL CURRENT BOOST CONNECTIONS FOR IC PEAK GREATER THAN 1.5A

1a. External NPN Switch

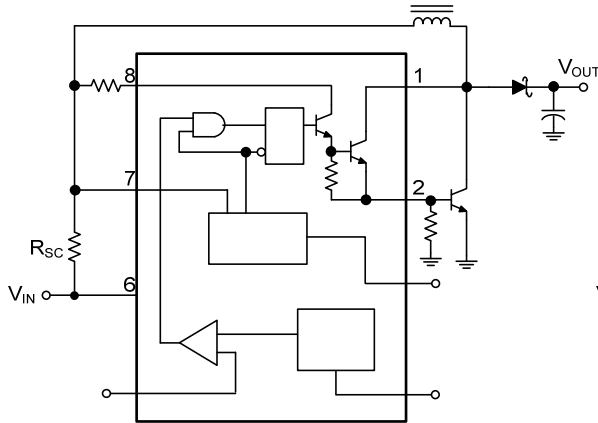

1b. External NPN Saturated Switch
(See Note 4)

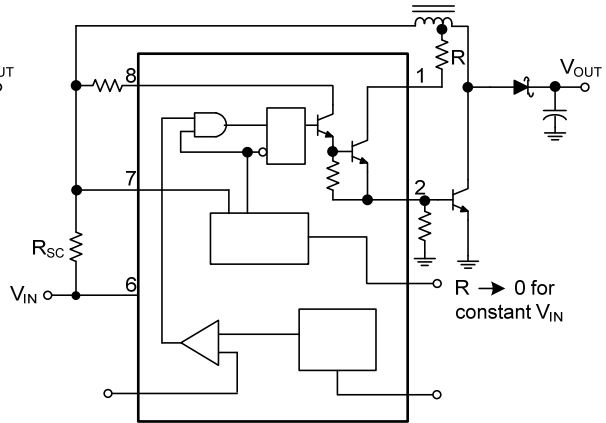

Note: 4. If the output switch is driven into hard saturation (non-Darlington configuration) at low switch currents ($\leq 300\text{mA}$) and high driver currents ($\leq 30\text{mA}$), it may take up to $2.0\mu\text{s}$ to come out of saturation. This condition will shorten the off time at frequencies $\geq 30\text{kHz}$, and is magnified at high temperatures. This condition does not occur with a Darlington configuration, since the output switch cannot saturate. If a non-Darlington configuration is used, the following output drive condition is recommended.

2a. External NPN Switch

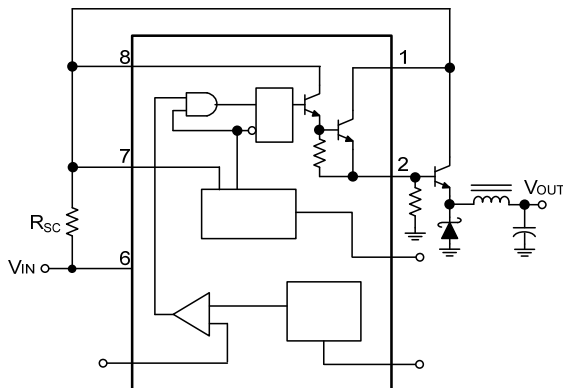

2b. External PNP Saturated Switch

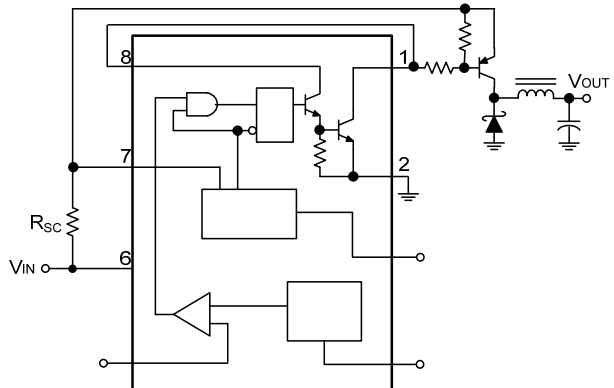

3a. External NPN Switch

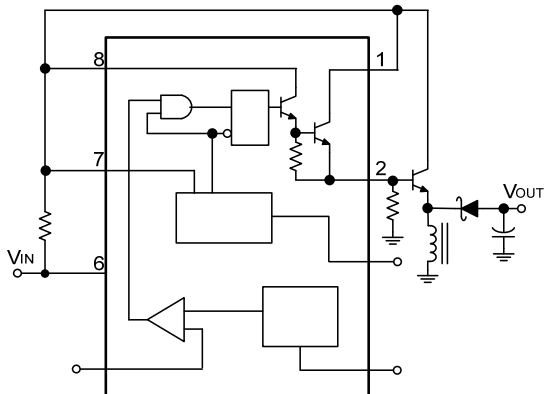

3b. External PNP Saturated Switch

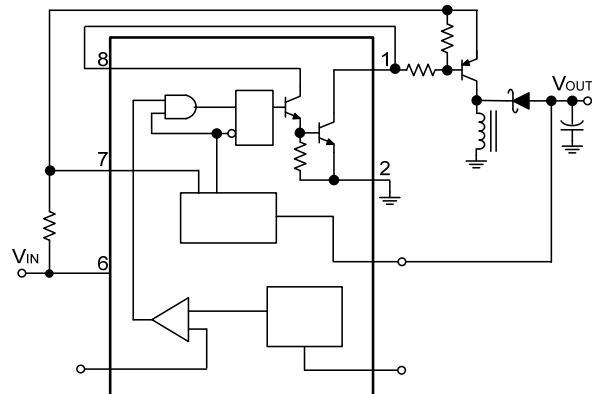

TYPICAL CHARACTERISTICS

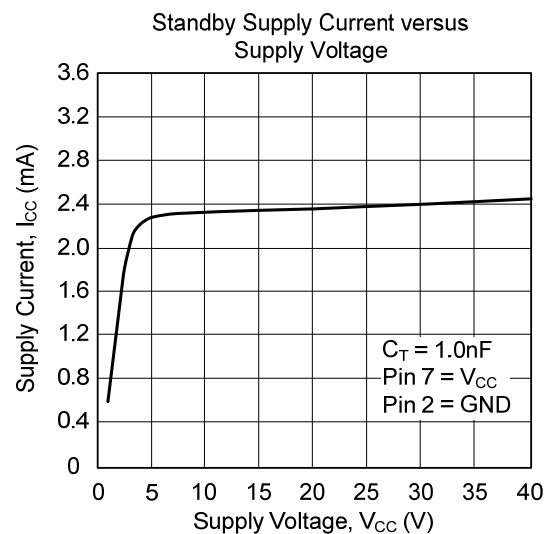
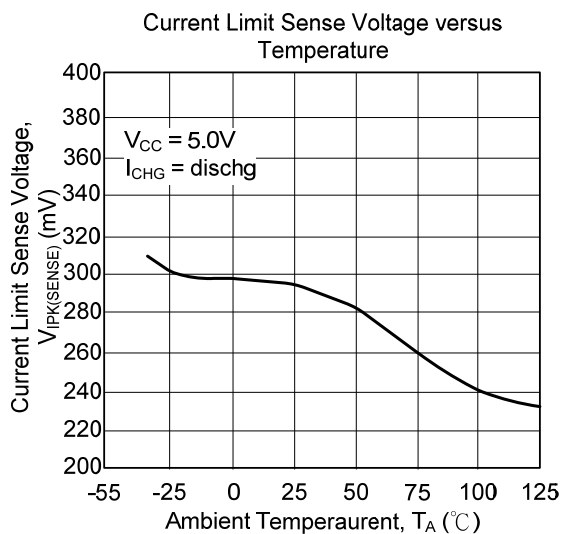
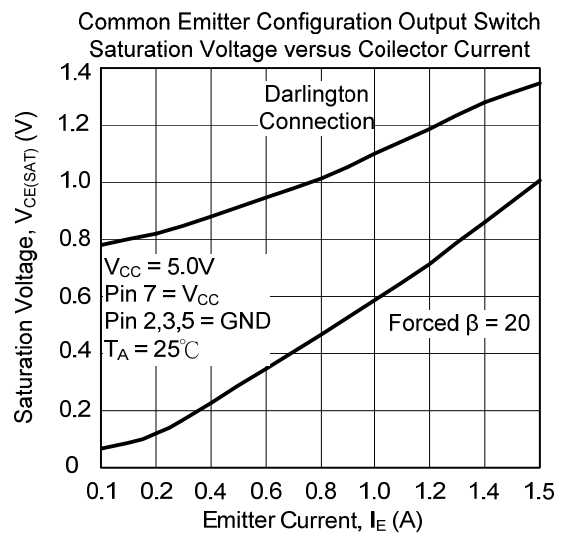
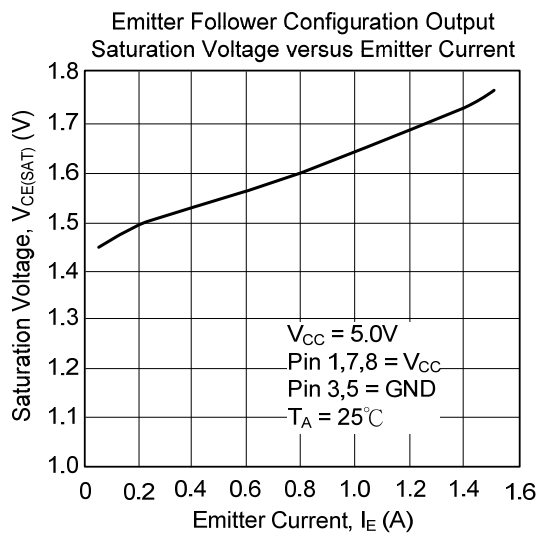
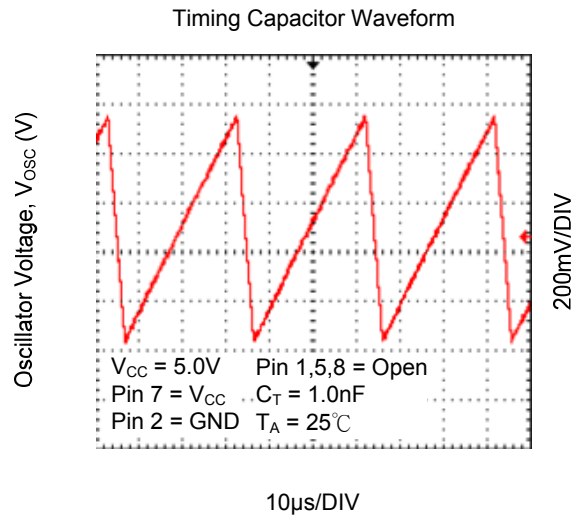
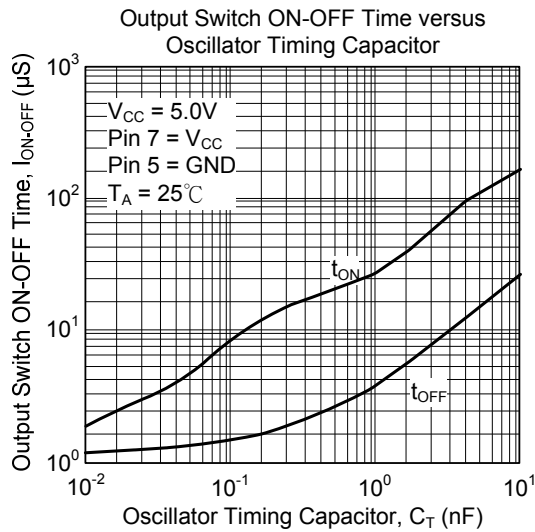

■ DESIGN FORMULA TABLE

CALCULATION	STEP-DOWN	STEP-UP	VOLTAGE-INVERTING
$\frac{t_{ON}}{t_{OFF}}$	$\frac{V_{OUT} + V_F}{V_{IN(MIN)} - V_{CE(SAT)} - V_{OUT}}$	$\frac{V_{OUT} + V_F - V_{IN(MIN)}}{V_{IN(MIN)} - V_{CE(SAT)}}$	$\frac{ V_{OUT} + V_F}{V_{IN} - V_{CE(SAT)}}$
$(t_{ON} + t_{OFF})_{MAX}$	$\frac{1}{F_{MIN}}$	$\frac{1}{F_{MIN}}$	$\frac{1}{F_{MIN}}$
C_T	$4 \times 10^{-5} t_{ON}$	$4 \times 10^{-5} t_{ON}$	$4 \times 10^{-5} t_{ON}$
I_{SW}	$2I_{OUT(MAX)}$	$2I_{OUT(MAX)} \frac{t_{ON} + t_{OFF}}{t_{OFF}}$	$2I_{OUT(MAX)} \frac{t_{ON} + t_{OFF}}{t_{OFF}}$
R_S	$0.3/I_{SW}$	$0.3/I_{SW}$	$0.3/I_{SW}$
$L_{(MIN)}$	$(\frac{V_{IN(MIN)} - V_{CE(SAT)} - V_{OUT}}{I_{SW}}) t_{ON(MAX)}$	$(\frac{V_{IN(MIN)} - V_{CE(SAT)}}{I_{SW}}) t_{ON(MAX)}$	$(\frac{V_{IN(MIN)} - V_{CE(SAT)}}{I_{SW}}) t_{ON(MAX)}$
C_O	$\frac{I_{SW}(t_{ON} + t_{OFF})}{8V_{RIPPLE(P-P)}}$	$\frac{I_{OUT} t_{ON}}{V_{RIPPLE(P-P)}}$	$\frac{I_{OUT} t_{ON}}{V_{RIPPLE(P-P)}}$

$V_{CE(SAT)}$ - Saturation voltage of the output switch.

V_F - Forward voltage drop of the ringback rectifier.

The following power supply characteristics must be chosen:

V_{IN} - Nominal input voltage.

V_{OUT} - Desired output voltage, $|V_{OUT}| = 1.25(1 + R_2/R_1)$

I_{OUT} - Desired output current.

F_{MIN} - Minimum desired output switching frequency at the selected values for V_{IN} and I_{OUT} .

$V_{RIPPLE(P-P)}$ - Desired peak-to-peak output ripple voltage. In practice, the calculated value will need to be increased due to the capacitor equivalent series resistance and board layout. The ripple voltage should be kept to a low value since it will directly effect the line and load regulation.

UTC assumes no responsibility for equipment failures that result from using products at values that exceed, even momentarily, rated values (such as maximum ratings, operating condition ranges, or other parameters) listed in products specifications of any and all UTC products described or contained herein. UTC products are not designed for use in life support appliances, devices or systems where malfunction of these products can be reasonably expected to result in personal injury. Reproduction in whole or in part is prohibited without the prior written consent of the copyright owner. The information presented in this document does not form part of any quotation or contract, is believed to be accurate and reliable and may be changed without notice.